

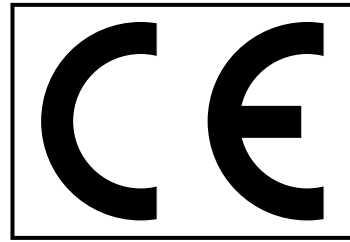

BS EN ISO 9001  
Certificate No. FM 15094



Affirmed by  
Declaration of Conformity

**Amplicon products are designed and manufactured in the United Kingdom under a quality system approved by the British Standards Institution**

---

# MODEL 485Fi

---

---

OPTO-ISOLATED

---

SIGNAL

---

LEVEL

---

ADAPTOR

---

RS-232

---

TO RS-422/485

---

This Instruction Manual is supplied with the Model 485Fi Adaptor to provide the user with sufficient information to utilise the purchased product in a proper and efficient manner. The information contained has been reviewed and is believed to be accurate and reliable, however **Amplicon Liveline Limited** accepts no responsibility for any problems caused by errors or omissions. Specifications and instructions are subject to change without notice.

**Model 485Fi Instruction Manual Part N° 859 459 44 Issue A4**

© **Amplicon Liveline Limited**

Prepared by C.A. Kenny

Approved for issue by A.S. Gorbald, Operations Director

## **DECLARATION OF CONFORMITY**

**AMPLICON LIVELINE LIMITED  
CENTENARY INDUSTRIAL ESTATE  
HOLLINGDEAN ROAD  
BRIGHTON BN2 4AW UK**

We declare that the product(s) described in this Instruction Manual are manufactured by Amplicon Liveline Limited and perform in conformity with the following standards or standardisation documents:

**Electro Magnetic Compatibility (EMC):**

EMC Directive 89/336/EEC  
LVD Directive 73/23/EEC  
CE Directive 93/68/EEC



Jim Hicks, I. Eng, MIEIE  
Managing Director  
Amplicon Liveline Limited

## Model 485Fi

# Opto-isolated RS-232 to RS-422/485 Adaptor

### LIST OF CONTENTS

PARA	SUBJECT	PAGE
1	INTRODUCTION	5
1.1	General Description	5
1.2	Technical Features	5
1.3	Important Notes for Existing model 485 Users	6
1.4	What the Package Contains	6
1.5	The Amplicon Warranty Covering the Model 485Fi Adaptor	7
1.6	Contacting Amplicon Liveline Ltd for Support or Service	7
1.6.1	Technical Support	7
1.6.2	Repairs	7
2	INSTALLATION INSTRUCTIONS	8
2.1	Requirements of Host Equipment	8
2.2	Connections to Model 485Fi Adaptor	8
2.2.1	RS-232 Connections on 25 way D Connector	8
2.2.2	RS-422/485 Connections on 8 way Pluggable Terminal Strip	9
2.3	Configuration of Model 485F9 Adaptor Options	9
2.4	Full Duplex / Half Duplex Operation	11
2.4.1	Selection of Full / Half Duplex	11
2.5	Selection of Transmit Enable Control Signal	12
2.6	Selection of Local Echo On/Off in Half Duplex Operation	13
2.7	Transmission Line Termination	13
2.7.1	Network Biasing Resistors	13
2.8	RS-232 Level Configuration	14
2.9	Power Requirements	14
2.9.1	Connecting the Amplicon Mains Adaptors	15
2.10	Software Installation	15
2.11	Installation Testing	15
3	APPLICATION INFORMATION	16
3.1	Why Isolate?	16
3.2	Applicable Standards	18
3.3	RS-232 Application Notes	18
3.3.1	Electrical Levels	18
3.3.2	9/25 Way Adaptors	19
3.4	RS-422/485 Application Notes	19
3.4.1	RS-422/485 Signalling sense	19
3.4.2	RS-422/485 Parameters	20
3.4.3	Cabling of RS-422 / 485 Bus	20
3.4.4	Multi-drop Applications	21
3.4.5	Bus Termination	22

<b>PARA</b>	<b>SUBJECT</b>	<b>PAGE</b>
4	TESTING AND TROUBLESHOOTING	23
4.1	Basic Testing and Fault Isolation	23
4.1.1	Testing with the Application Software	23
4.1.2	Loop-back Testing Using a Simple BASIC Program	23
4.1.3	Further Investigations	24
5	TECHNICAL INFORMATION	26
5.1	Technical Specification	26
5.1.1	Electrical Specification	26
5.1.2	Physical/Environmental Specification	26
5.2	Circuit Details	27
5.2.1	Circuit and Layouts	27
5.2.2	Circuit Operation	27
5.3	Optional Accessories	28
5.3.1	U.K. Mains Adaptor Power Supply	28
5.3.2	International Mains Adaptor Power Supply	28
	USER'S NOTES	32

#### LIST OF FIGURES

<b>FIG N°</b>	<b>TITLE</b>	<b>PAGE</b>
2.1	RS-232 Connections	8
2.2	RS-422/485 Connections	9
2.3	Opening the Plastic Case	9
2.4	Configuration Options	10
2.5	Connections for Full and Half Duplex Operations	11
2.6	External Transmitter Enable Connections	12
2.7	Network Biasing Resistors	14
2.8	Power Supply Connections for Single 485Fi Adaptor	14
3.1	Elimination of interfering Signals by Isolation	17
3.2	DTE Adaptor - 9 Way to 25 Way	19
3.3	Standard RS-232/422/485 Parameters	20
3.4	RS-422 Connected in Broadcast Mode	21
3.5	RS-485 Connected in Multi-drop, Half Duplex Mode	22
4.1	Terminal Links for Loop-back Test	23
5.1	Model 485Fi Circuit Schematic	29
5.2	Model 485Fi Printed Circuit Board Layouts	30

## 1. INTRODUCTION

### 1.1 General Description

The Model 485Fi Adaptor is a compact, plug-in unit providing **fully isolated**, bi-directional conversion of serial data communications signals between the following standards:-

RS-232  $\longleftrightarrow$  RS-422      OR      RS-232  $\longleftrightarrow$  RS-485

The Model 485Fi Adaptor is equipped with a 25 way, female D type connector for direct plug-in connection to an RS-232 device configured as DTE, such as a Personal Computer. When properly powered from an external, isolated supply, the adaptor translates the bi-directional transmit and receive signal levels from one standard to the other. The RS-232 device hardware handshaking lines are looped back, and the RS-232 Request To Send (RTS) control line can be used for RS-485 transmission turnaround if required. The pin-out configuration is in accordance with the RS-232 25 pin standard. The adaptor itself is not considered as DTE or DCE, and where these terms are used, they apply to the RS-232 equipment to which the Model 485Fi Adaptor is connected.

A high level of electrical isolation is provided between the two ports, with each port referred to its own ground potential. Isolation is provided by opto-couplers on data and control signal lines, and the Model 485Fi Adaptor will tolerate noise or offset between PC and isolated ground terminals of 75 Vpk without data corruption.

RS-485 multi-drop operation allows up to 32 devices to be connected in a simple network on a single serial bus. The transmitter has a tri-state output and may be disabled to allow reception over the same wire pair. The high impedance state (transmitter disabled) is commanded from an external control signal or from the host computer RTS line.

DC power for the Model 485Fi Adaptor must be applied from an external, isolated source. The DC power is referred to the RS-422/485 ground of the remote device, and the DC power lines plus the RS-422/485 data and control signals are connected through a pluggable 8 way screw terminal assembly at the free end of the Adaptor.

#### EMC Considerations

In order to maintain compliance with the EMC directive, 89/336/EEC, it is mandatory that the final system integrator uses good quality screened cables for external connections. It is up to the final system integrator to ensure that compliance with the Directive is maintained. Amplicon Liveline offers a series of good quality screened cables for this purpose. Please contact our sales staff.

### 1.2 Technical Features

- Full opto-isolation between the RS-232 and RS-422/485 ports
- RS-422 or RS-485 compatible
- Multi-drop capability
- Plugs directly into standard 25 pin male connector
- Configured for operation with DTE host
- Single power supply connection. Polarity protected
- Remote connections via pluggable terminal strip
- Compact and versatile

### **1.3 Important Notes for Existing Model 485 Users**

1. For enhanced ESD protection, the Model 485Fi Adaptor has the RS-422/485 interface ground connections on the outer pins. This requires minor wiring changes for existing users of earlier, non-isolated versions of the Amplicon 485 Adaptors
2. For conformance with the latest RS-422/485 standard specifications, the nomenclature of the data lines is amended. The RS-422/485 levels and polarities remain unchanged and the actual external data bus wiring needs no changes
3. To take advantage of the isolation provided by the 485Fi, care must be taken to ensure that the external power source maintains the isolation
4. The RS-232 interface is self-powered and this feature relies on the RTS and/or DTR control lines providing the necessary drive for the data signals. RTS and/or DTR must therefore be programmed ON (positive control signal output) for the Model 485Fi to operate correctly. Some RS-232 devices fall short of the published specifications for transmit and/or receive operations, and these devices may fail to operate with the 485Fi

### **1.4 What the Package Contains**



## **CAUTION**

Some of the components on the board are susceptible to electrostatic discharge, and proper handling precautions should be observed. As a minimum, an earthed wrist strap must be worn when handling the 485Fi Adaptor outside its protective bag.

Full static handling procedures are defined in British Standards Publication BSEN100015/BSEN100015-1:1992.

When removed from the bag, inspect the board for any obvious signs of damage and notify Amplicon if such damage is apparent. Do not apply power to a damaged board and do not plug it into the host computer. Keep the protective bag for possible future use in transporting the module.

1. The Model 485Fi Adaptor board with 8 way free socket and the plastic case disassembled. The plastic case should not be snapped together until any necessary configuration changes have been made.

The complete 485Fi Adaptor is supplied under Amplicon order code 909 459 43

2. This 485Fi Instruction / Reference manual. Amplicon part number 859 459 44

Any additional accessories (mating gender changers, power supply etc.) may be packed separately.

## **1.5 The Amplicon Warranty Covering the Model 485Fi Adaptor**

This product is covered by the warranty as detailed in the Terms and Conditions stated in the current domestic or international **Amplicon Liveline** catalogue.

Changes made in accordance with the guidelines given in this manual will not void this warranty unless any damage is a direct consequence of mishandling.

**DO NOT MAKE ANY MODIFICATIONS TO A PRODUCT THAT IS ON EVALUATION.**

## **1.6 Contacting Amplicon Liveline Limited for Support or Service**

The Model 485Fi Adaptor is designed and manufactured by Amplicon Liveline Ltd. Maintenance is available throughout the supported life of the product.

### **1.6.1 Technical Support**

Should the Model 485Fi Adaptor appear defective, please check the information in this manual to ensure that the product is being correctly applied. If an application problem persists, please request Technical Support on one of the following numbers:

Telephone:	UK	01273 608 331
	International	+44 1273 608 331
Fax:	UK	01273 570 215
	International	+44 1273 570 215
Internet	support@amplicon.co.uk www.amplicon.co.uk	

### **1.6.2 Repairs**

If the Model 485Fi Adaptor requires repair then please return the goods enclosing a repair order detailing the nature of the fault. If the product is still under warranty, which is for a period of 12 months from the date of shipment, there will be no repair charge unless the fault has been caused by misuse.

For traceability when processing returned goods, a Returned Materials Authorisation (RMA) procedure is in operation. Before returning the goods, please request an individual RMA number by contacting Amplicon Customer Services by telephone or fax on the above numbers. Give the reason for the return and, if the goods are still under warranty, the original invoice number and date. Repair turnaround time is normally five working days but the Service Engineers will always try to co-operate if there is a particular problem of time pressure.

Please mark the RMA number on the outside of the packaging to ensure that the package is accepted by the Goods Inwards Department.

Address repairs to: Customer Services Department  
AMPLICON LIVELINE LIMITED  
Centenary Industrial Estate  
Brighton, East Sussex  
BN2 4AW  
England

## **2. INSTALLATION INSTRUCTIONS**

### **2.1 Requirements of Host Equipment**

The Model 485Fi Adaptor can be plugged into any device with an RS-232 port terminating in a 25 way D type male connector (DB-25) and configured as Data Terminal Equipment (DTE). The Adaptor can be directly plugged into this port and held in position by its jack screws.

In addition to the 25 pin D connector, many RS-232 interface connectors comply with the 9 pin (DB-9) standard. In addition, DIN, mini-DIN and other types of connector are sometimes used for RS-232 ports. If the pin connections of the host device interface are known, then enough information is given in this manual to make up a suitable adaptor connection cable.

If isolation is not required, several types of 485 Adaptor are available from Amplicon Liveline Ltd to mate with male or female versions of the DB-25 connector and male versions of the standard 9 pin (DB-9) connector.

### **2.2 Connections to Model 485Fi Adaptor**

Connections are made to the Model 485Fi Adaptor at each end of the module, with the isolation barrier internally positioned between the two ports. The RS-232 connections are automatically made when the Adaptor is plugged into the port, and the RS-422/485 data, control and power connections must be made through a pluggable 8 way screw terminal connector assembly at the free end.

#### **2.2.1 RS-232 Connections on 25 way D Connector**

The connections conform to the RS-232 25 way pin-out standard, and are shown in figure 2.1 below. The diagram shows the connector as viewed from the face of the socket mounted on the Model 485Fi Adaptor, and mates with the normal DTE pinout.

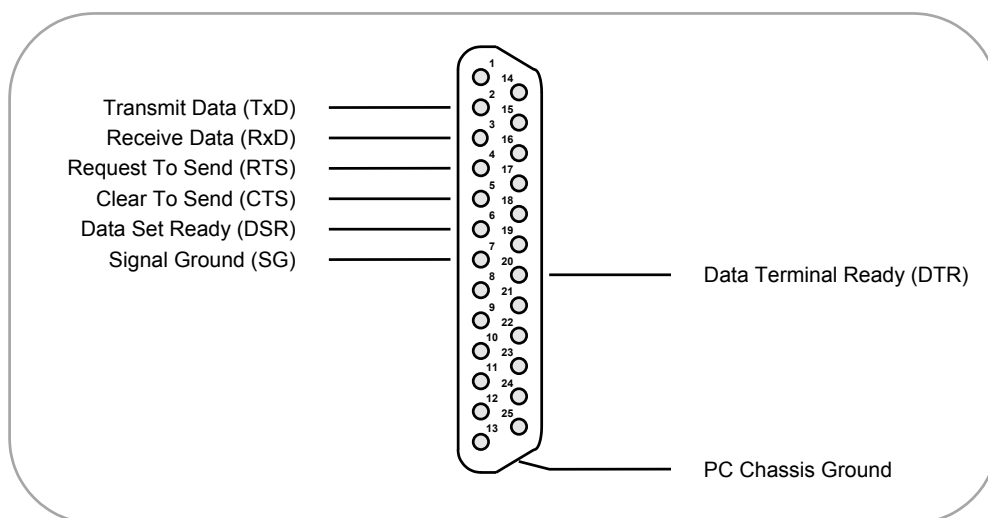
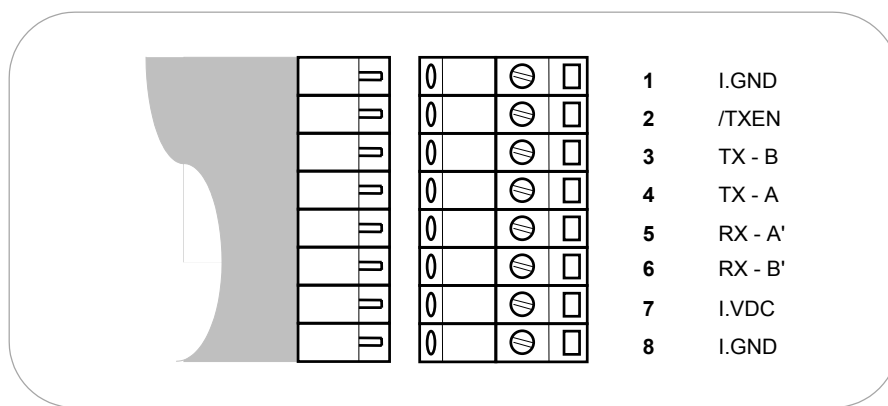

**FIGURE 2.1 RS-232 CONNECTIONS**

## 2.2.2 RS-422/485 Connections on 8 way Pluggable Terminal Strip

The DC power input, RS-485 transmission turnaround external control signal and RS-422/485 data signal connections are made via an eight way screw terminal connector. The supplied connector can be unplugged from the Adaptor for ease of making the cables without removing the Adaptor from the port.

The connector pinouts are shown in figure 2.2 below. The diagram shows the connector as viewed from the top face of the Model 485Fi Adaptor. The abbreviated function names are printed on the PCB extension below the fixed part of the connector. Note that for conformance with current standards, ESD requirements and to maintain isolation, the connection configuration is similar, but not identical, to other 485 Adaptors in the Amplicon range.

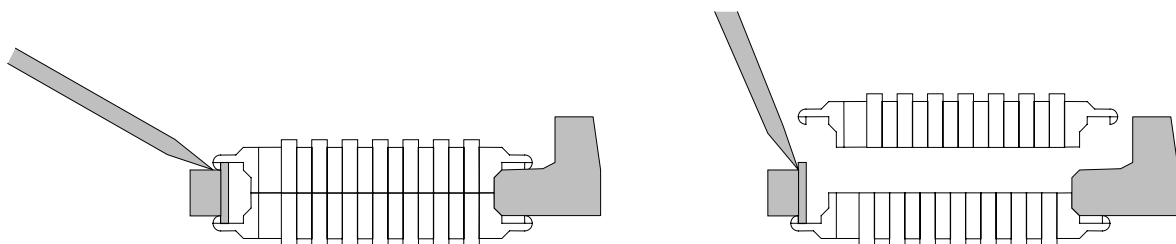

**FIGURE 2.2 RS-422/485 CONNECTIONS**

## 2.3 Configuration of Model 485Fi Adaptor Options

Configuration of the options is undertaken by jumpers on the component side of the Model 485Fi Adaptor printed circuit board and, if necessary, by removal of a link on the reverse side. The Adaptor as supplied is configured to suit the majority of applications requiring full duplex operation or half duplex with echo.

For convenience, the plastic case is supplied in two parts and should only be clipped together when any configuration changes have been made. Operational tests can be performed before the case is fitted. If the case halves have been snapped together, they may be parted using a small flat-bladed screwdriver to pop open the case. The technique is shown in figure 2.3 below.



**FIGURE 2.3 OPENING THE PLASTIC CASE**

The configuration options listed in the table below are available, and the appropriate jumpers and link positions are shown in figure 2.4.

Jumper/Link	Default Position	Default Function	Alternative Position	Alternative Function
Jumper J1	OUT	External Tx Enable	IN	RTS Tx Enable
Link J2	Bridged	Rx Terminator in circuit	Track open	Rx Terminator out
Jumper J3	OUT	Receive enable/Echo ON	IN	Half duplex echo OFF
Jumper J4	IN	RS-232 normal level	OUT	RS-232 high level

The jumper, link and wiring configuration options are described in more detail in paragraphs 2.4 through 2.8. For many applications, no changes need be made, but if re-configuration is required, locate the jumper or link from figure 2.4 which diagrammatically illustrates both sides of the printed circuit board.

The jumpers J1 and J3 as supplied are hung on a single pin so that the connection is not made and jumper J4 is supplied in the inserted position. To re-configure the Transmit Enable to the RTS setting, insert the jumper J1 across the two pins of the J1 header (see para 2.5). To turn the Echo OFF in half duplex mode, insert the jumper J3 across the two pins of the J3 header (see para 2.6). To re-configure the RS232 drive level for higher output, remove jumper J4 (see para 2.8). When any existing jumper connection is not needed, remove the jumper and hang it on a single pin for safe keeping.

In the unlikely circumstance that the receiver termination resistor needs to be taken out of circuit (see para 2.7), locate the J2 pad group from figure 2.4 illustration of the non-component side of the printed circuit board. When the J2 link is not needed, cut the copper tie with a craft knife or remove any solder bridge with a desoldering tool. To re-make the link, the pads are placed close enough that a solder bridge can be re-made without using wire. Before applying power to the Adaptor, inspect the changes carefully to ensure that the solder has properly wetted the pads and that no other bridges have been made.

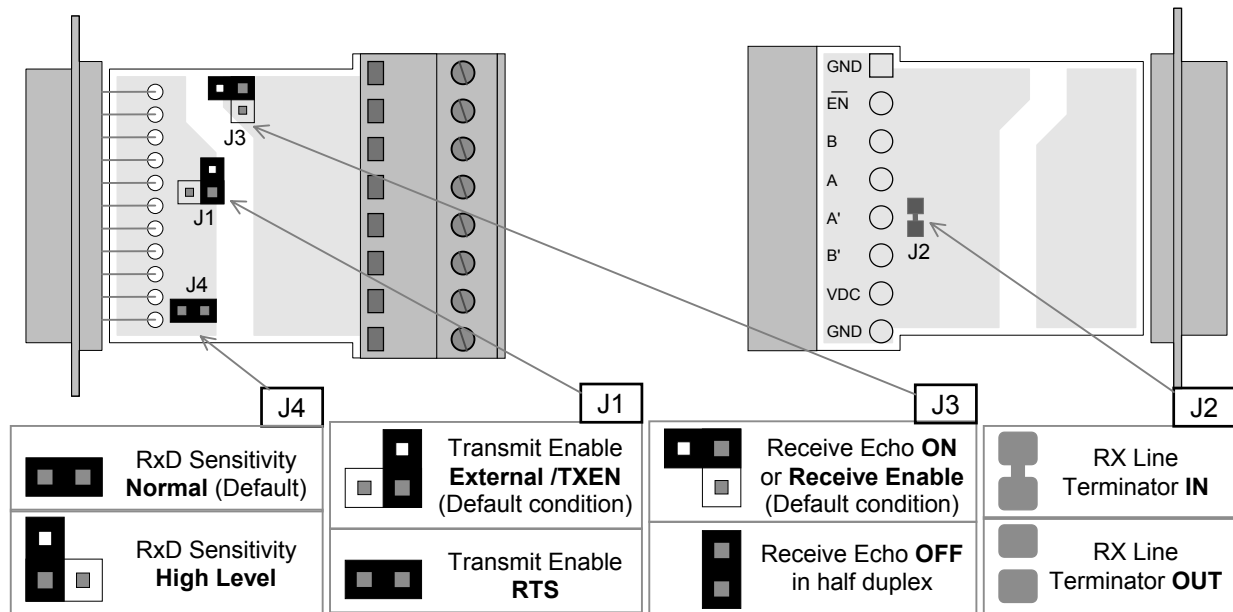

FIGURE 2.4 CONFIGURATION OPTIONS

## 2.4 Full Duplex / Half Duplex Operation

The Model 485Fi Adaptor can be used in either full duplex (simultaneous transmission and reception over two independent wire pairs) or half duplex (sequential transmission or reception over a single wire pair).

In full duplex operation, a separate transmitter and receiver circuit is employed, and in this mode the transmitter and receiver can be left in their enabled states at all times. In half duplex operation, the transmitter output and receiver input wire pairs are connected in parallel, and the transmitter must be disabled by switching to its high impedance state when allowing reception of data over the same serial lines. In half duplex, the receiver can either be permanently enabled (J3 OUT) when the Tx data signals are echoed, or can be disabled during transmission (J3 IN) when the echo is suppressed.

The Model 485Fi Adaptor is provided with all the data input/output terminals required for full duplex operation. **If half duplex working is required, then the following external and internal configuration changes must be considered.** Also check that the termination resistor, paragraphs 2.7 and 3.4.5, is correctly set for the system in use.

### 2.4.1 Selection of Full/Half Duplex

In the full duplex condition, the serial RS-422/485 signals are transmitted over the twisted wire pair TX - A and TX - B and the incoming signals are received on RX - A' and RX - B'. In half duplex operation, the data signals are both transmitted and received on the two pairs externally wired in parallel. Figure 2.5 below illustrates the Transmit (Tx) and Receive (Rx) wiring for each mode.

Jumper J3 must always be OUT for full duplex operation, but may be IN to suppress echos in half duplex operation.

See the Applications Section 3 for further information on wiring of the signal lines and ground connections.

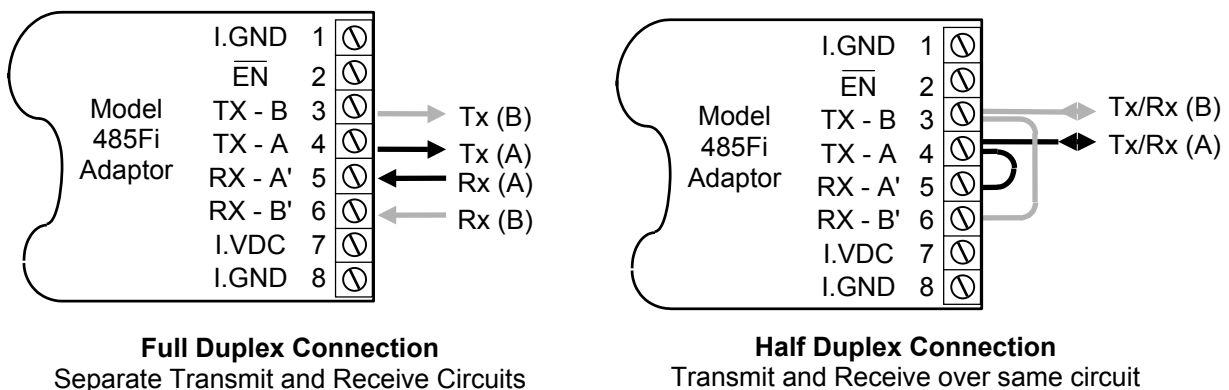

**FIGURE 2.5 CONNECTIONS FOR FULL AND HALF DUPLEX OPERATION**

## 2.5 Selection of Transmit Enable Control Signal

In half duplex operation over a single circuit or a multi-drop arrangement, the transmitter must be enabled when the device is ready to transmit, and disabled (tri-state) when the device is ready to receive. Two methods are provided for enabling the transmitter, and the desired method is selected by the jumper J1. (See figure 2.4).

1. **External  $\overline{\text{TXEN}}$ .** With the External  $\overline{\text{TXEN}}$  (Not Transmit Enable) option selected on J1, the transmit enable is under the control of a TTL level signal applied to terminal 2 ( $\overline{\text{EN}}$ ) of the connector strip. This control signal is active low, and is internally pulled down when no signal is applied. In full duplex or transmit only operation, this control line can be left open-circuit, when the transmitter will be continuously enabled. THIS SIGNAL IS REFERRED TO THE POTENTIAL OF THE ISOLATED GROUND (I.GND).

In externally controlled half duplex operation, or any other situation where the transmitter requires external control, the signal applied to terminal 1 for enabling or disabling the transmitter must not exceed the following levels:-

ENABLE TRANSMITTER '0' (Active Low)	Input low	> - 25 V < +0.8 V
DISABLE TRANSMITTER '1'	Input high (V)	> +3.0 V < +25.0 V at <1.6 mA

Figure 2.6 below shows how the external control connection is made. Note that the power supply voltage VDC applied to pin 7 is in the range for disabling the transmitter, and can be used in conjunction with switch or relay contacts to turn transmission around.

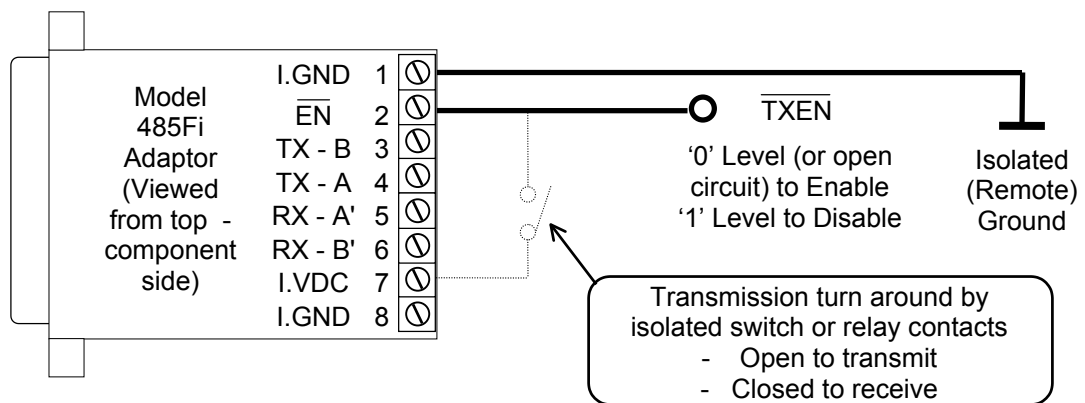

**FIGURE 2.6 EXTERNAL TRANSMITTER ENABLE CONNECTIONS**

2. **RTS Transmit Enable.** The transmitter can alternatively be enabled under control of the RTS (Request To Send) line of the RS-232 host DTE device. See J1 in figure 2.4 for the appropriate jumper patching. No connection must be made to external  $\overline{\text{TXEN}}$  when RTS is controlling the transmission turnaround.

In normal RS-232 DTE operation, RTS is raised to its ON (positive) state when the device is ready to commence transmission. In many circumstances, the use of RTS provides a simple means of enabling the transmitter. However, check overall system timing before using this control method.

An example of programming the RTS bit to effect communication turnaround is given in the following BASIC program fragment. In the normal 8250, 16450 etc type of UART, RTS is bit 1 of

the Modem Control Register which is found at the channel base address BA+04. The default logic '1' at /RTS sets the transceiver to receive and the active logic '0' sets it to transmit.

```
regs=inp(BA+4)           'Input register contents
regs=regs OR &H02        'Force bit 2 high for transmit
regs=regs XOR &H02       'Force bit 2 low for receive
out(BA+4),regs           'Output to modem register
```

When the RTS signal is being used for transmission control, the RTS output is still linked to return the signal on the CTS input lines and CTS can be monitored on bit 4 of the Modem Status Register to determine the instantaneous state of the transmission direction.

Further information on half duplex and multi-drop operation is given in the applications section of this manual.

## 2.6 Selection of Local Echo On/Off in Half Duplex Operation

The factory default configuration of jumper J3 causes the transmitted data to be echoed to the receiver in half duplex operation. If this echo is not required, the jumper must be inserted (see paragraph 2.3). This change ensures that the RS-485 receiver is enabled/disabled in opposite phase to the transmitter. For full duplex operation, the link J3 must be in its default (out) condition for the receiver to be continuously enabled. Echo is not appropriate to full duplex operation.

## 2.7 Transmission Line Termination

In RS-422 or RS-485 applications, the two wire transmission lines must be properly terminated, and a single resistor across the receiver input pair normally provides adequate termination.

The Model 485Fi Adaptor is equipped with a terminator resistor for the receiver input pair, and this resistor is connected into circuit by the J2 copper link on the printed circuit board. See figure 2.4. Factory setting is with the receiver input terminator in circuit, but it can be disconnected from the circuit by cutting the link as described in paragraph 2.3. Disconnection of the termination resistor is required in some multi-drop applications.

See the applications section of this manual for a discussion of bus termination.

### 2.7.1 Network Biasing Resistors

In some instances, particularly in RS-485 multi-drop operation, noise may be detected at the receiver. In the multi-drop configuration, there can be brief periods when no transmitter is enabled, and the network is therefore allowed to float. The Model 485Fi Adaptor is protected against this condition, but other devices on the network may be susceptible to noise and are liable to float to a potential that is detected as an input. The programmer can sometimes overcome this situation by ensuring that the communications protocol flushes the input buffer until the beginning of the message flag is found.

If this problem is encountered and a software solution is not viable, two extra resistors can be added externally to the 485Fi transceiver at one end of the bus, so that the network is biased to about 1 to 2 volt when all transmitters are disabled. The internal termination resistor must be kept in circuit. The arrangement is shown in figure 2.7.

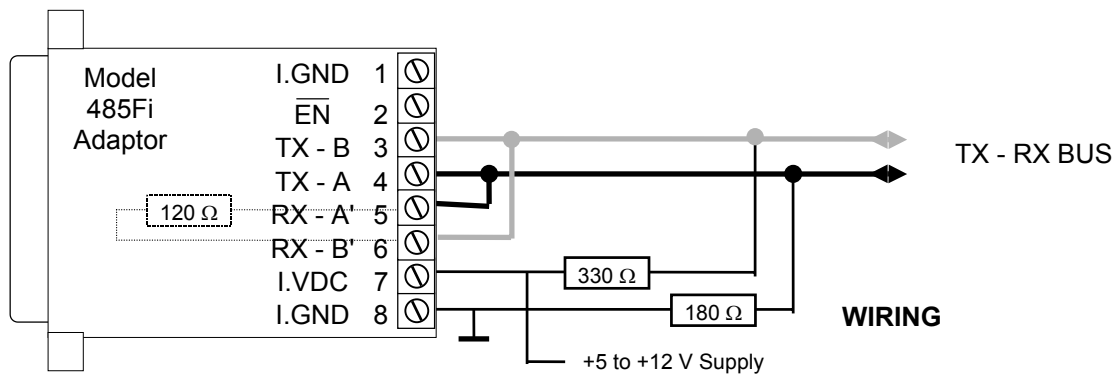

**FIGURE 2.7 NETWORK BIASING RESISTORS**

## 2.8 RS-232 Level Configuration

Tests on a variety of host PCs and different RS-232 driver boards have shown that there are many creative interpretations of the RS-232 interface specification. The 485Fi Adaptor as supplied will operate correctly with the majority of known RS-232 devices, but if a problem is encountered, removing jumper J4 increases the output signal voltages for devices requiring these high levels.

To check the operation, run a test program, or the simple loop-back test given in paragraph 4.1.2, and view the received data. If no data or intermittent characters are received, remove jumper J4 and continue running the test. If characters are still not properly received, suspect another problem and refer to paragraph 4.1.3

## 2.9 Power Requirements

The Model 485Fi Adaptor must be powered from an isolated external power supply providing a positive output of between +5.0 VDC and +12.0 VDC. This auxiliary power supply unit should be capable of sourcing at least 100 mA for the 485 Adaptor that it supplies. **As the power supply maintains the isolation, only one 485Fi Adaptor can be fed from a single supply.** Amplicon Mains adaptors meet these requirements and the U.K. plug-in version is available under order code 919 135 69, International wired-in version is order code 919 448 69. See paragraph 2.9.1 for information on connecting these power supplies to the Model 485Fi terminals. These mains power adaptors should not be used when the common mode potential difference across the isolation barrier is likely to exceed 75 Vpk.

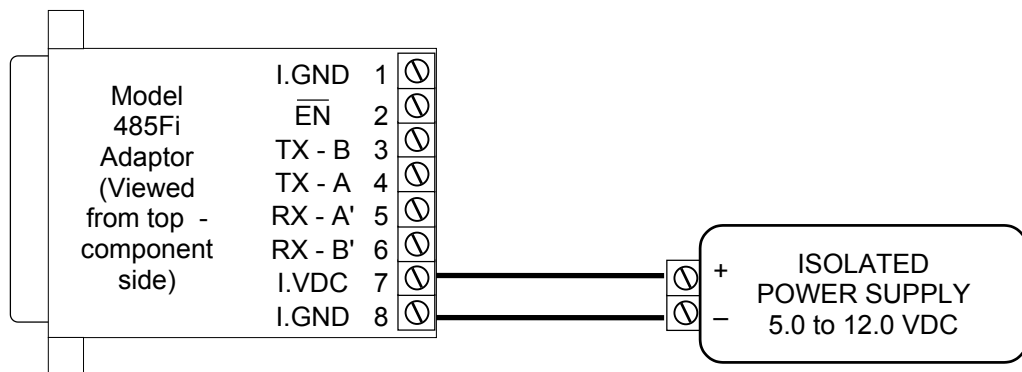

**FIGURE 2.8 POWER SUPPLY CONNECTIONS FOR SINGLE MODEL 485Fi ADAPTOR**

The 485Fi Adaptor is fitted with an eight way pluggable terminal strip at its free end, and the power supply should be connected to terminals 7 and 8. Terminal 8 is Isolated Ground or negative and terminal 7 is the positive supply. OBSERVE POLARITY when powering the adaptor. If the polarity is incorrect, the 485Fi Adaptor will not operate, but is protected against damage. A wiring diagram for applying power to a single 485Fi Adaptor is shown in figure 2.8.

### **2.9.1 Connecting the Amplicon Mains Adaptors**

The U.K. version of the optional mains adaptor plugs directly into a 3 pin, 13 A mains socket. The International version is fitted with a Continental 2 pin plug which, if necessary, may be cut off and a different plug fitted. The mains supply voltage must be 230 VAC  $\pm 10\%$ , 50 Hz.

The DC output is by a two wire cable approximately 2 m in length. This cable is terminated in a moulded connector which must be cut off and discarded. The two wires can then be parted and stripped back about 6 mm. The black wire is negative and goes to terminal 8 (I.GND) of the 485Fi Adaptor, and the black wire with a white stripe is positive and goes to terminal 7 (I.VDC). Section 5.3 gives the Amplicon order codes for the above adaptors.

### **2.10 Software Installation**

Software is not supplied with the 485Fi Adaptor, but a choice of suitable software packages is available from Amplicon Liveline Ltd. to allow easy integration of serial communications into the user's application.

The 485Fi Adaptor connected via an existing RS-232 port will operate in conjunction with many commercially available communications and data acquisition packages that support RS-232, RS-422 or RS-485 serial operations. The software should be installed according to the supplier's instructions, and due note should be taken of the required settings for the communications channels, and the communications circuit configurations set accordingly.

The following software limitations should be remembered when allocating COM channels:-

MS-DOS 3.3 and above supports COM1, COM2, COM3 and COM4.

Other operating systems allow the use of more than two ports. Check the instructions.

Most BASIC language interpreters/compiler only support COM1 and COM2.

Communications support toolkits such as Amplicon 'COMBIOS for DOS' and 'COMBIOS for Windows' allow add-on serial ports to several different language compilers.

### **2.11 Installation Testing**

Many applications packages include a self test feature, and when the hardware and software have been satisfactorily installed, any such test should be performed to check correct operation.

If no self test is available, or a problem occurs, see the later section 4, 'TESTING AND TROUBLESHOOTING'.

### 3. APPLICATION INFORMATION

As previously noted, many applications packages are designed to support data transfer over the RS-422 or RS-485 standard serial communications ports. When set up as specified, the interface will be transparent to the user. However, for special applications, particularly when isolation and the use of the RS-485 interface is required, the following notes will be helpful.

#### 3.1 Why Isolate?

The Model 485Fi Adaptor provides complete electrical isolation between any signals connected to the RS-422/485 serial port and the circuits of the host computer. In a compact office or laboratory environment such isolation may not be necessary, however in a wide-field industrial situation, serial digital communication can be disrupted by many types of contaminating signals, most of which can be eliminated by the proper use of isolation.

Another common requirement for isolation occurs when one of the two connected devices has its mains supply through an earth leakage or residual current breaker. Connecting the grounds can cause the breaker to trip, and ground isolation eliminates this problem.

The input receivers and output drivers make use of opto-couplers to provide a signal path between external and internal circuits without any electrical connection being made. An opto-coupler comprises a Light Emitting Diode (LED) which is turned on by the incoming signal, and a photo-detector which receives the light and converts it into an electrical signal. The emitter and detector are mounted in a package that provides a light path together with high voltage insulation between the two sides. The RS-232 interface is self-powered and the power to the RS-422/485 input/output circuits is provided by an isolated, external power supply.

Interfering signals can come from a variety of sources and are often greater in amplitude than the desired signal. Such an interfering signal is 'common mode' and is effectively the potential difference between the zero-signal reference points of the signal source and receiver. By using the Model 485Fi Isolated Signal Adaptor, this potential difference appears across the isolation barrier and not in series with the signal as would be the case if direct connection was employed.

	<b>BE AWARE</b>
<b>DANGER</b> High Voltage	<b>DANGER OF ELECTRIC SHOCK</b>
	When the Model 485Fi Isolated signal Adaptor is in use, voltages up to 75 Vpk or higher under fault conditions may be exposed on the connector and associated circuitry.

The two ends of a link would normally have their grounds connected together through the signal ground line, the protective ground line and/or the cable shield. Such a connection has an impedance such that an interfering signal caused by a difference in ground potentials is likely to be a few volts in amplitude, maybe peaking to tens of volts. However there may be circumstances or fault conditions in which higher common mode voltages exist, and the circuits of the Model 485Fi Adaptor is designed to operate with peak common mode voltages up to 75 V peak without data corruption. Under fault conditions, the unit will hold off higher peak common mode voltages without damage.

**BE AWARE THAT THE EXTERNAL POWER SUPPLY USED WITH THE 485Fi ADAPTOR MUST ALSO BE CAPABLE OF WITHSTANDING THE HIGH POTENTIAL DIFFERENCE.** The Mains Adaptors available from Amplicon Liveline should not be used with common mode voltages greater than 100 Vpk.

RS-232 standards allow a transition region of  $\pm 3.0$  V, and within this region, signal variations will not be detected. If the signal (real or noise) is  $< -3.0$  V, it will be detected as a mark for a data line or OFF for a control line. If the signal is  $> +3.0$  V, it will be detected as a space for data or ON for a control signal. RS-422 and RS-485 standards provide a better level of ground noise immunity than RS-232, the maximum common mode voltages being  $-7.0$  V to  $+7.0$  V and  $-7.0$  V to  $+12.0$  V respectively for the two standards. **However, any ground offset, noise, hum or other interference exceeding these peak amplitudes will be detected as real signals and corrupt the data or control functions.**

Breaking the common ground connection by the use of the Model 485Fi isolated interface completely eliminates the detection of these interfering signals as real signals with no loss or corruption of data.

In general, isolation is only required at one end of a data link, and figure 3.1 illustrates the principle of the isolated interface and shows how the signal loop is self-contained and not subject to common mode interference.

Multi-drop or broadcast systems with many RS-485 or RS-422 nodes on a single circuit may require some or all circuits to be isolated for error free serial data communication.

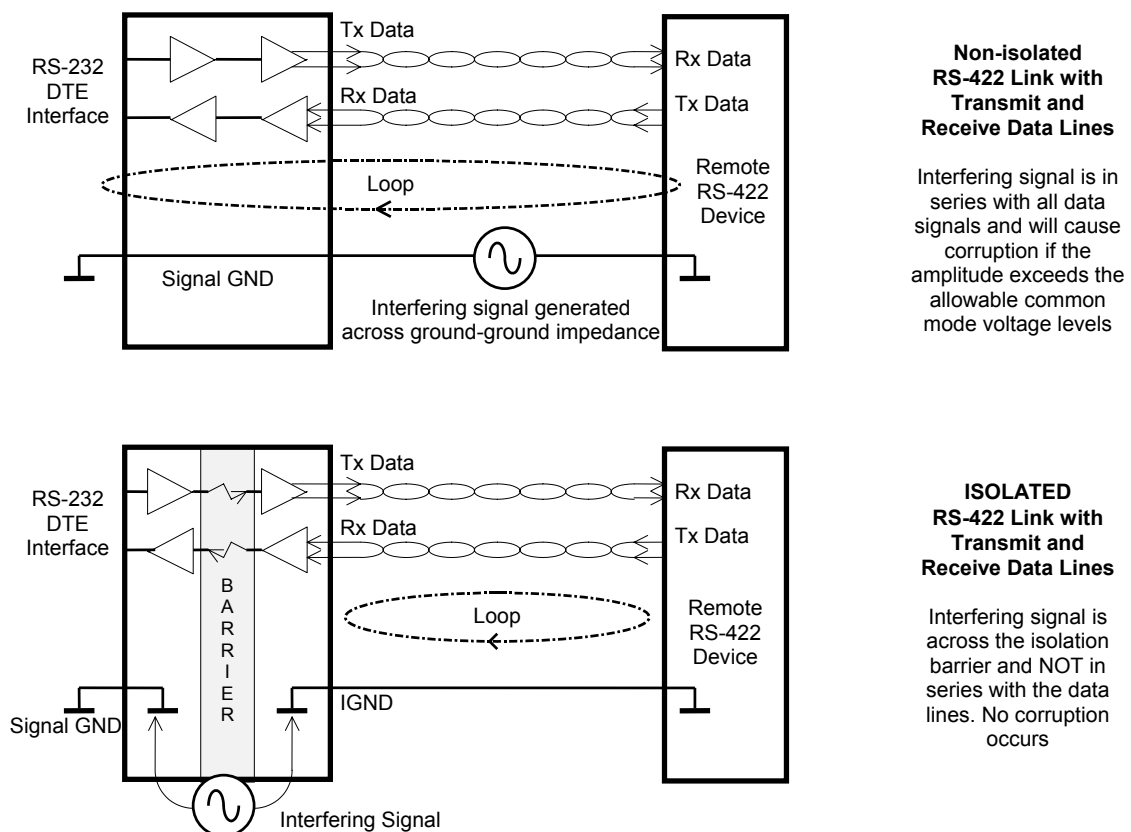

**FIGURE 3.1 ELIMINATION OF INTERFERING SIGNALS BY ISOLATION**

### **3.2 Applicable Standards**

The prefix 'RS' signifies Recommended Standard, and the three interface types, RS-232, RS-422 and RS-485, are all well defined in the appropriate standards publications. The functions and features of the data interfaces presented by the Model 485Fi Adaptor generally conform to normal industry practice employing subsets of the full standards.

The RS-232 serial interface standard is now at revision E and its full title is EIA (Electronic Industries Association) TIA RS-232-E, *"Interface Between Data Terminal Equipment and Data Communication Equipment Employing Serial Data Interchange"*. Similar European standards CCITT V.24 and V.28 define an interface which is operationally compatible with RS-232.

The RS-232 connection of the Model 485Fi Adaptor is for equipment configured as DTE (Data Terminal Equipment), and the Adaptor has a female connector.

The RS-232 standard specifies a 25 pin connector, but the full 25 connector pins are not required to support the common functions of RS-232 as used by the Model 485 range of adaptors, and IBM and other manufacturers frequently adopt a 9 way D connector that provides all the necessary functionality. The Model 485Fi Adaptor complies with the 25 pin convention and there may be occasions where a 9/25 pin conversion cable or adaptor such as the Amplicon PC-AT Serial Port Adaptor 909 245 77 is useful. Paragraph 3.3.2 gives the connection details for making up a suitable converter cable.

The RS-422 interface is defined in the EIA standard RS-422-B, *"Electrical Characteristics of Balanced Voltage Digital Interface Circuits"*.

As stated, this standard defines the electrical characteristics but does not specify a connector type or pin-out configuration. The Model 485 Adaptor meets the RS-422 standard electrical specification with communication via an 8 way terminal strip connector wired as shown in the installation diagrams.

The RS-485 specification is also published as an EIA standard and is closely allied to the RS-422. The 485 Adaptor meets the requirements for data signals as laid down in the standard.

### **3.3 RS-232 Application Notes**

RS-232 was approved as a standard interface in 1969. Before and since that time, this interface in its various revisions has been very popular despite its many shortcomings and usage outside of its intended role. Most small computers now have an RS-232 interface as standard, or easily added, and many peripherals and instruments also support this serial interface, but not all in the same way. Hence an RS-232 application needs careful study of the host equipment manufacturers connections and methods before the Model 485Fi Adaptor is installed. However RS-232 lines are quite safe if wrongly connected, so the experimental use of a break-out box or 'hit and miss' methods of establishing communication can be employed.

#### **3.3.1 Electrical Levels**

When checking out serial communications circuits, it is useful to know what signal levels to expect. The specified voltage levels of RS-232 data and control signals are summarised in the following table:-

Interchange Voltage	-3 to -15	+3 to +15
Binary State	1	0
Data Signal (TXD)	Marking	Spacing
Control Function (RTS, DTR)	OFF	ON

Signal Ground is at 0 volts, and the region between -3 and +3 volts is the transition region, but RS-232 receivers normally accept a 0 to -15 volt signal as a 1 (Marking)

As the Model 485Fi Adaptor RS-232 interface is self powered, the host computer interface must provide at least +6.0 V output level when ON ('0' or Spacing), and the Request to Send (RTS) and/or Data Terminal Ready (DTR) control lines must be turned ON. The RS-232 receiver must accept  $0 \pm 0.5$  V as a '1' (Marking). These requirements are met by the all RS-232 host devices using industry standard driver/receivers.

The Model 485Fi Adaptor will normally be used in close proximity to the RS-232 port, but in a case where it is not directly plugged in, any RS-232 to RS-232 connecting cable should not be more than 2 m in length

### 3.3.2 9/25 way Adaptors

The wiring list in figure 3.1 shows the necessary connections to adapt a 9 way RS-232 port to a 25 way RS-232 port, or vice versa. Due note should be taken of the gender of the mating connector, and a gender change can be incorporated in the adaptor if required.

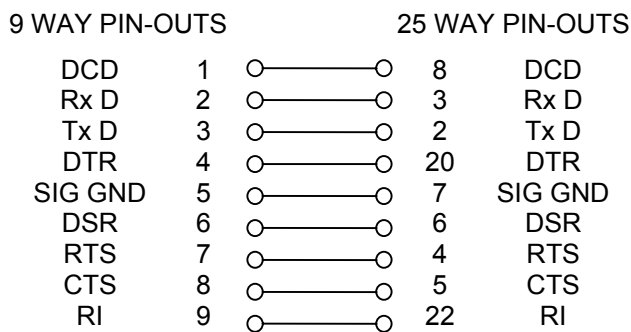

**FIGURE 3.2 DTE ADAPTOR - 9 Way to 25 Way**

### 3.4 RS-422/485 Application Notes

RS-422 and RS-485 have very similar characteristics, with RS-485 being compatible with, and offering all the advantages of RS-422 plus some additional capability. RS-422 pre-dated RS-485 as a standard, but RS-485 is now more popular and used in new system design. For the 485 Adaptor, the on board circuitry for the two modes is identical, the application deciding the mode of interface operation.

#### 3.4.1 RS-422/485 Signalling Sense

The RS-422 and RS-485 standards define the polarity of the signalling lines as follows, and the Model 485Fi is in accordance with these specifications.

"The signalling sense of the voltages appearing across the interconnecting cable is defined as follows:

- a. The A terminal of the generator shall be negative with respect to the B terminal for a binary 1 (MARK or OFF) state
- b. The A terminal of the generator shall be positive with respect to the B terminal for a binary 0 (SPACE or ON) state"

**3.4.2 RS-422/485 Parameters**

The following table in figure 3.2 summarises the principal parameters of the RS-422-B and RS-485 standards, and shows RS-232 for comparison.

EIA STANDARD	RS-232	RS-422-B	RS-485
Mode of Operation	Single ended	Differential	Differential
Number of Drivers and Receivers on line	1 Driver 1 Receiver	1 Driver 10 Receivers	32 Drivers 32 Receivers
Max. Cable Length	15 m	1200 m	1200 m
Max. Data Rate	20 kBd	10 MBd	10 MBd
Max. Common Mode	N/A	+7 V, -7 V	+12 V, -7 V
Driver Voltage	±5 V to ±15 V	±2 V min	±1.5 V min
Driver Load	3 kΩ to 7 kΩ	100 Ω min	60 Ω min
Driver Slew rate	30 V/μs	N/A	N/A
Driver Output Short Circuit Limit	500 mA to Vcc or Ground	150 mA to Ground	150 mA to Gnd 250 mA to Vcc
Receiver Input Resistance	3 kΩ to 7 kΩ	4 kΩ	12 kΩ
Receiver Sensitivity	±3 V	±200 mV	±200 mV
Receiver Hysteresis	1.15 V	50 mV	50 mV

**FIGURE 3.3 STANDARD RS-232/422/485 PARAMETERS**

**3.4.3 Cabling of RS-422/485 Bus**

RS-232 data transmission rates are specified up to 20 kBd but are sometimes as high as 115 kBd. The Model 485Fi Adaptor can be used up to 20 kBd and the maximum RS422/485 cable length of 1200m will apply at all usable data rates.

RS-422/485 employs a differential method of signal transmission, and each bus cable has to be a wire pair, preferably twisted and screened to keep induced noise to a minimum. The bus distribution cable is effectively a transmission line, and appropriate techniques should be used for installation of the cables. In a multi-drop environment, the cable should be 'looped through' each device, or if a spur is necessary, the spur length should be kept to a minimum.

If screened cable is used, some thought must be given to the connection of the screen. This screen should not normally be used as a ground return for non-isolated devices, but can be used as a return for isolated devices.

**3.4.4 Multi-drop Applications**

RS-422 can provide limited multi-drop capability, using two twisted wire pairs in a broadcast mode. One wire pair connects one transmitter to multiple receivers, but if duplex operation is required, only one receiving station can answer back. See figure 3.3.

Isolated or non-isolated 485 Adaptors may be used in combination in multi-drop applications. In general, if several devices are in close proximity, these devices need not be isolated as ground-ground potentials are not likely to exceed the common mode voltage limits. If one or more devices are at more remote locations, then it may be advisable to use isolated 485Fi Adaptors at these distant locations only.

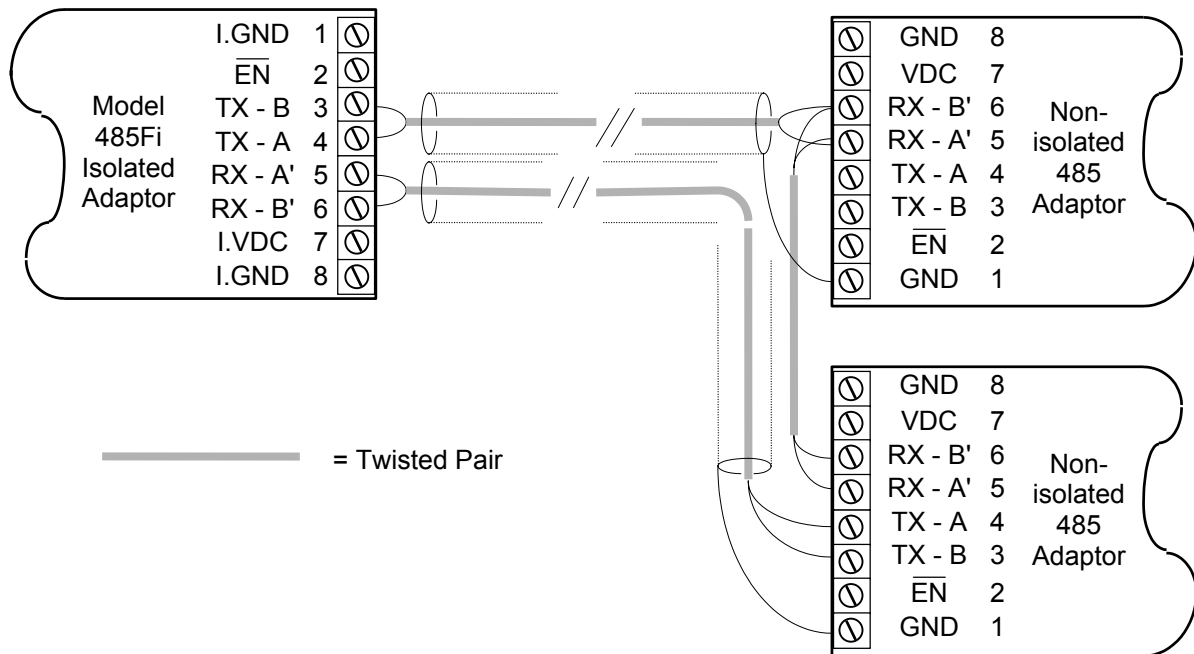

**FIGURE 3.4 RS-422 CONNECTED IN BROADCAST MODE**

RS-485 allows multiple (up to 32) transmitters and receivers to be connected in half duplex on a single twisted wire pair for 'party line' type of communications. See figure 3.4. A method must be used to stop more than one transmitter being on the line at any time, ensuring that all other transmitters are in a high impedance state, although the circuit design is such that no damage will be done to the transceivers if several transmitters are turned on together. In a multiple RS-485 transmitter installation, the application program controls the data communication turnaround and the selection of the bus 'talker'.

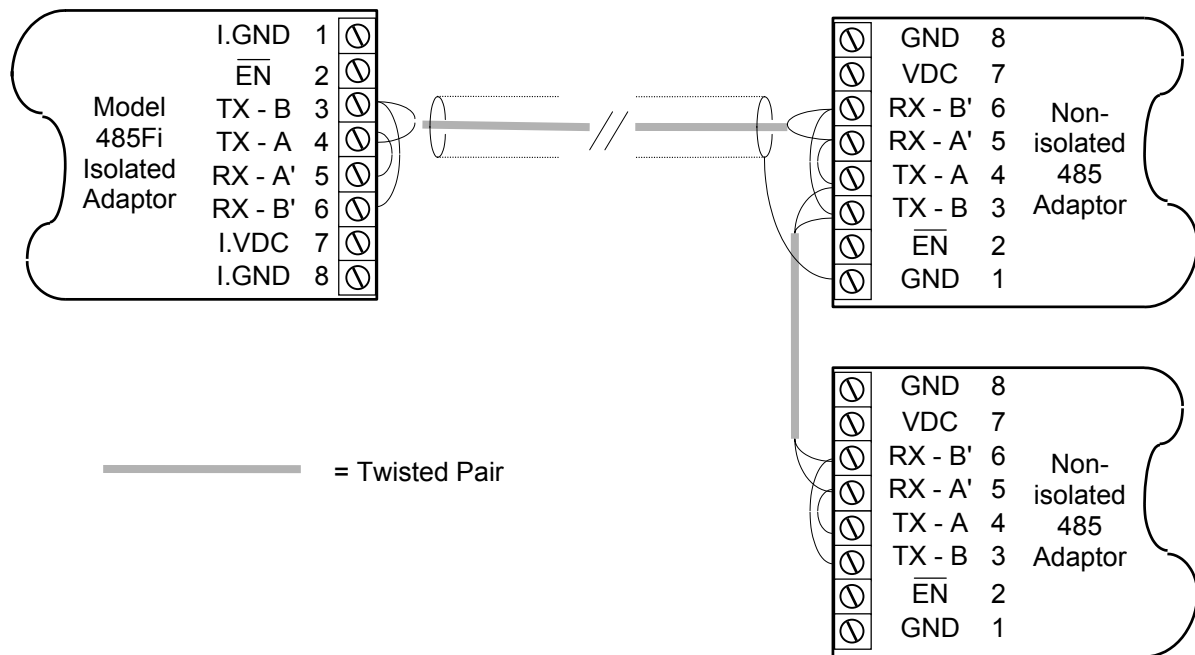

**FIGURE 3.5 RS-485 CONNECTED IN MULTI-DROP, HALF DUPLEX MODE**

Two common ways of providing program control are the 'Master / Slave' and 'Token Ring' methods. The 'Master / Slave' method designates one device on the network as Master, and this device supervises all transmissions by communicating with each of the Slaves in turn and offering it a transmission slot. In token ring operation, each device knows its ID neighbour and only talks directly to this next device. Thus communication only occurs between adjacent pairs of devices and this makes for a flexible network but can be a more difficult method to implement.

The Model 485 Adaptor provides a method of communication turnaround by enabling the 'ON' transmitter using an external control signal or RTS from the RS-232 port. Default condition of the Model 485 Adaptor enables the transmitter, so that for full duplex operation of RS-422/485 no control signal is required. See paragraph 2.5 for further information.

### 3.4.5 Bus Termination

For proper operation of the RS-422/485 bus in full or half duplex, multi-drop or point-to-point communication, it is recommended that termination is applied to the receiver end of the data lines. The simplest form of termination is line-to-line with typically a 120 Ω resistor across the differential input, and this terminator is available on the Model 485Fi Adaptor board, selectable by link J2.

In a multi-drop system, the terminator resistor is only required at the device receiver located at the far end of the cable. If this is in half duplex operation, then both ends of the bus cable are equipped with receivers (transceivers) so termination is necessary at both ends. Although the 485Fi Adaptor will drive loads as low as 27 Ω, in general, RS-485 transmitter circuits are specified as being capable of driving a minimum load resistance of 60 Ω, so no more than two terminator resistors should be connected in parallel to any one bus.

## 4. TESTING AND TROUBLESHOOTING

### 4.1 Basic Testing and Fault Isolation

If the installation instructions have been correctly followed, and the serial communications port is being used in conjunction with a proven software driver, then it is unlikely that any problems will be experienced in establishing communications through the serial interface.

When difficulties do occur, the following notes may be helpful in isolating the problem area.

#### 4.1.1 Testing with the Application Software

Before testing, ensure that the Model 485Fi Adaptor is properly configured for the application. Use the test mode of the application program, and if a problem occurs, it is often possible to test the system using the looped back RS-232 port without the Model 485Fi Adaptor. This test will identify that a problem is in the adaptor, its configuration or use.

#### 4.1.2 Loop-back Testing Using a Simple BASIC Program

The Model 485Fi Adaptor can be tested away from external influences such as the signal cables, other devices and the applications program by performing the following loop-back test. It is necessary to link the terminals as shown in figure 4.1, and run the 4 line BASIC program given below. A copy of a BASIC interpreter such as QuickBASIC or GWBASIC will be required.

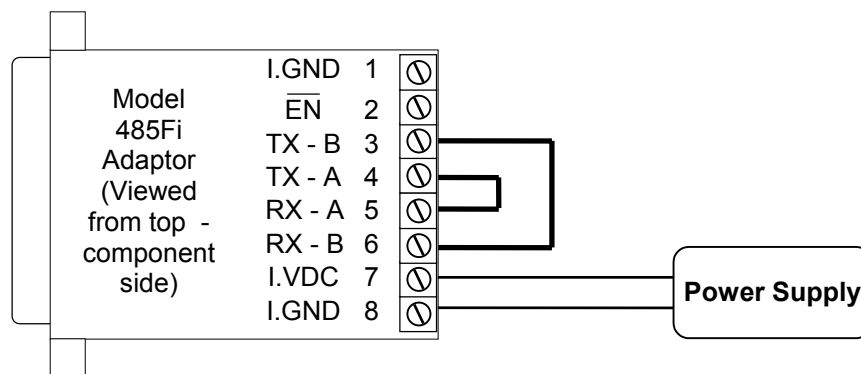

**FIGURE 4.1 TERMINAL LINKS FOR LOOP-BACK TEST**

The base address of the channel under test should be set to 3F8 (COM1) and the channel interrupt to IRQ4. The test can also be undertaken at 2F8 (COM2) and IRQ3 by changing the first line of the program accordingly.

To test the RS-422/485 port, the following 485Fi Adaptor configuration settings must also be checked. This is the default configuration.

- |           |   |                               |
|-----------|---|-------------------------------|
| <b>J1</b> | <b>(Jumper out)</b>   | <b>External Tx Enable</b>     |
| <b>J2</b> | <b>(Link made)</b>  | <b>Terminator Resistor In</b> |
| <b>J3</b> | <b>(Jumper out)</b>   | <b>Echo ON</b>                |
| <b>J4</b> | <b>Set as appropriate for host RS-232 device (see para 2.8)</b> |                               |

The test sends the message "Loop-back test passed" from the RS-422/485 port and reads it back into the LB\$ variable. The message is then printed once to the screen. This test encompasses proper operation of both the RS-232 data and control interface and the RS-422/485 data lines.

```
10 OPEN "com1:2400,n,8,1" FOR RANDOM AS #1

20 mcr% = INP(&H3F8 + 4)
30 mcr% = mcr% OR 1
40 OUT &H3F8 + 4, mcr%

50 PRINT #1, "Loop-back test passed"
60 lb$ = INPUT$( (21), #1)
70 PRINT lb$
```

### **Comments**

Line numbers can be omitted in most modern BASICs such as QuickBASIC

This program assumes the serial interface is directly compatible with an 8250, 16450 etc type of UART

Line 10 Configures com port COM1 to 2400 Baud, no parity, 8 data bits and 1 stop bit. This works equally well with COM2 and other communications parameters. If changing to COM2, ensure that the register locations in lines 20 and 40 are also changed.

Line 20 Reads the current contents of the Modem Control Register on COM1's UART. This register is located at the COM port's base address (COM1=3F8 hex and COM2=2F8 hex) plus four. E.g 3F8+4

Line 30 This sets bit 0 of the Modem Control register (DTR to logic 1) leaving the others unaffected

Line 40 The newly changed byte is written back to the UART and the DTR line turns ON (positive) supplying power to the 485Fi RS-232 circuit

Line 50 The message 'Loop-back test passed' is output on the selected coms port

Line 60 The message, having been sent from the transmitter to the receiver via the loop-back connector, is read

Line 70 Displays the message

### 4.1.3 Further Investigations

If tests with the applications software or other loop-back tests indicate that the 485 Adaptor is working properly, but other problems persist, then the following should be investigated.

### **Communication circuits**

For a communications circuit to operate correctly, both ends of the circuit, and the interconnecting cables must be serviceable and the correct connections made. The vagaries of RS-232, RS-422 and RS-485 implementation often cause problems in making the proper

connections, and the manufacturers instructions for the equipment at each end should be carefully checked.

#### **Hardware handshaking control signals**

The self powered facility of the RS-232 interface of the 485Fi Adaptor requires that the device interface meets the minimum specification requirements and it must be ensured that **Data Terminal Ready (DTR) and/or Request To Send (RTS) control lines are ON (high)**. If RTS is being used for transmission enable in half duplex operation, then the program must ensure that DTR is ON (high) at all times.

#### **Polarity of RS-422/485 differential data lines**

Not all suppliers use the same convention for the polarity of the differential data lines. The Model 485Fi Adaptor lines are labelled A and B for the transmitter and A' and B' for the receiver as defined in the RS-422/485 specification. If the other device is labelled differently, then:-

**A** is normally connected to **A** or **A'** or **Y** or **High** or **+**  
**B** is normally connected to **B** or **B'** or **Z** or **Low** or **-**

If all devices are not so labelled and the polarity is not evident, or if a problem is suspected in this area, then some experimentation may be necessary. No damage can be done to the interface hardware by reversing polarity.

#### **Termination of Data and Control Lines**

The differential data lines must be properly terminated as described in paragraph 2.7

## 5. TECHNICAL INFORMATION

### 5.1 Technical Specification

The technical characteristics of the Model 485Fi Adaptor are in accordance with the following electrical and physical specifications. **Except where otherwise noted, all specifications are typical at 25° C**

#### 5.1.1 Electrical Specification

External Isolated Power Requirements	+5.0 VDC to +12.0 VDC from external isolated power supply via terminal strip. 100 mA required with full 485 bus load
Port to Port Isolation Voltage	Maximum noise or offset between PC and isolated ground terminals of 75 Vpk without data corruption.
RS-232 Tx Data Marking (from host)	< 0 V
RS-232 Tx Data Spacing (from host)	Must be > +6.0 V
RS-232 Control Signals (RTS and DTR from host)	
ON	Must be > +6.0 V
OFF	Must be < -6.0 V
RS-232 Rx Data Marking (from 485Fi)	< +1.0 V
RS-232 Rx Data Spacing (from 485Fi)	> +4.0 V
RS-422/485 Input sensitivity	0.2 V
RS-422/485 Input hysteresis	70 mV
RS-422/485 Output drive	1.5 V minimum, fully loaded
RS-422/485 Output load	27 Ω minimum
RS-422/485 Receiver I/P Termination	120 Ω resistor across differential input terminals. Can be disconnected by cutting link
RS-485 Tx enable	>-25.0 V, < +0.8 V or open circuit
RS-485 Tx disable	> +3.0 V, <+25.0 V
Tx disable input current	<1.6 mA (Input high)
Data rate	20 kBd max
RS-232 Connector	25 way DB-9 female connector with screw-locks
RS-422/485 Connector	8 way pluggable screw terminal assembly

#### 5.1.2 Physical/Environmental Specification

	<u>Module with connector</u>	<u>Packed</u>
Size	67 x 43 x 20 mm	215 x180 x 80 mm
Weight	60 gm	250 gm
Temperature Range	<u>Operating</u> 0° C to +60° C	<u>Storage</u> -20 to +70° C

## 5.2 Circuit Details

Sufficient details of the Model 485Fi Adaptor circuit and its operation are given for troubleshooting and repair by the user. The circuit diagram is also useful in understanding the operation of the various optional configurations.

Some of the components on the board are susceptible to electrostatic discharge, and proper handling precautions should be observed. As a minimum, an earthed wrist strap must be worn when handling the 485Fi Adaptor outside its protective bag.

### 5.2.1 Circuit and Layouts

The circuit diagram of the Model 485F1 Adaptor is given in figure 5.1, and the PCB component and copper side layouts are shown in figure 5.2.

### 5.2.2 Circuit Operation

**Function** The Model 485Fi Adaptor converts the electrical levels of signals from those specified for RS-232 to RS-422/485 levels and vice versa.

**Isolation** Electrical isolation between the ports is implemented by opto-couplers in the transmit (QA3), receive (QA1) and RTS control circuits (QA2). Each side of the barrier is powered separately.

**RS-232 Power** The RS-232 side is self powered and requires that the host device data and control signals exceed  $\pm 6.0$  V for proper operation. The voltage to drive the data line is derived from RTS and/or DTR through diodes D2 and D1, and one or both of these lines must always be ON (positive) to ensure proper operation and the derived voltage must be at least +5 VDC.

**RS422/485 Power** The RS-422/485 side is powered by an external, isolated power supply with regulation to +5 VDC provided by a protected series regulator Q1. This supply is referred to isolated ground, and must retain the isolation.

**Hardware Handshaking** The RS-232 port CTS input is linked to the RTS output to ensure that the RS-232 operation does not lock up awaiting a handshake signal. Similar to the above, the RS-232 port DSR input is linked to the DTR output

**Transmission Turnaround** With J1 out of circuit, transmission is turned round under the control of /TXEN on PL1/2. This line is normally pulled down by R6, and the transistor embedded in QA2 inverts this signal to enable the 485 transmitter in QA4. With J1 inserted RTS can also be used for transmission turnaround in half duplex and in this case no signal must be applied to the external /TXEN control line.

**Echo** With J3 out, the receiver in QA4 is permanently enabled, with incoming data always routed to the RS-232 device. This is the normal condition with full duplex operations, and in half duplex mode, both received data and transmitted data (echo) are sent to the RS-232 device. When J3 is in and the circuit is operating in half duplex, then the receiver in QA4 is enabled/disabled in opposite phase to the transmitter and the echo is not returned.

**RXD Pull Down** Dependant on the characteristics of the RS-232 receiver, the pull down resistor R10, R11 can be set as 1k5 or 9k7 by the position of J4.

### 5.3 Optional Accessories

#### 5.3.1 U.K. Mains Adaptor Power Supply

<b>Amplicon Order Code</b>	<b>Description</b>	<b>Function</b>
919 135 69	Plug-in mains adaptor	Provides +9 VDC at 200 mA to power a Model 485Fi Adaptor. Mains operated 230/240 VAC. Integral 3 pin, 13 A, UK style plug. Two wire output cable of 2 m length. Moulded connector to be removed for screw terminal connection to 485Fi Adaptor. Wire with white stripe is positive, see paragraph 2.4.1  The U.K. Mains Adaptor complies with the requirements of British Standard BS415

#### 5.3.2 International Mains Adaptor Power Supply

919 448 69	Wired-in mains adaptor	Provides +9 VDC at 200 mA to power a Model 485Fi Adaptor. Mains operated 220/230 VAC. Two wire (Brown - live, blue - neutral), 1.5 m length mains input cable fitted with two pin 'Continental' mains plug. Two wire output cable of 2 m length. Moulded power connector to be removed for screw terminal connection to 485Fi Adaptor. Wire with white stripe is positive, see paragraph 2.4.1
------------	------------------------	--

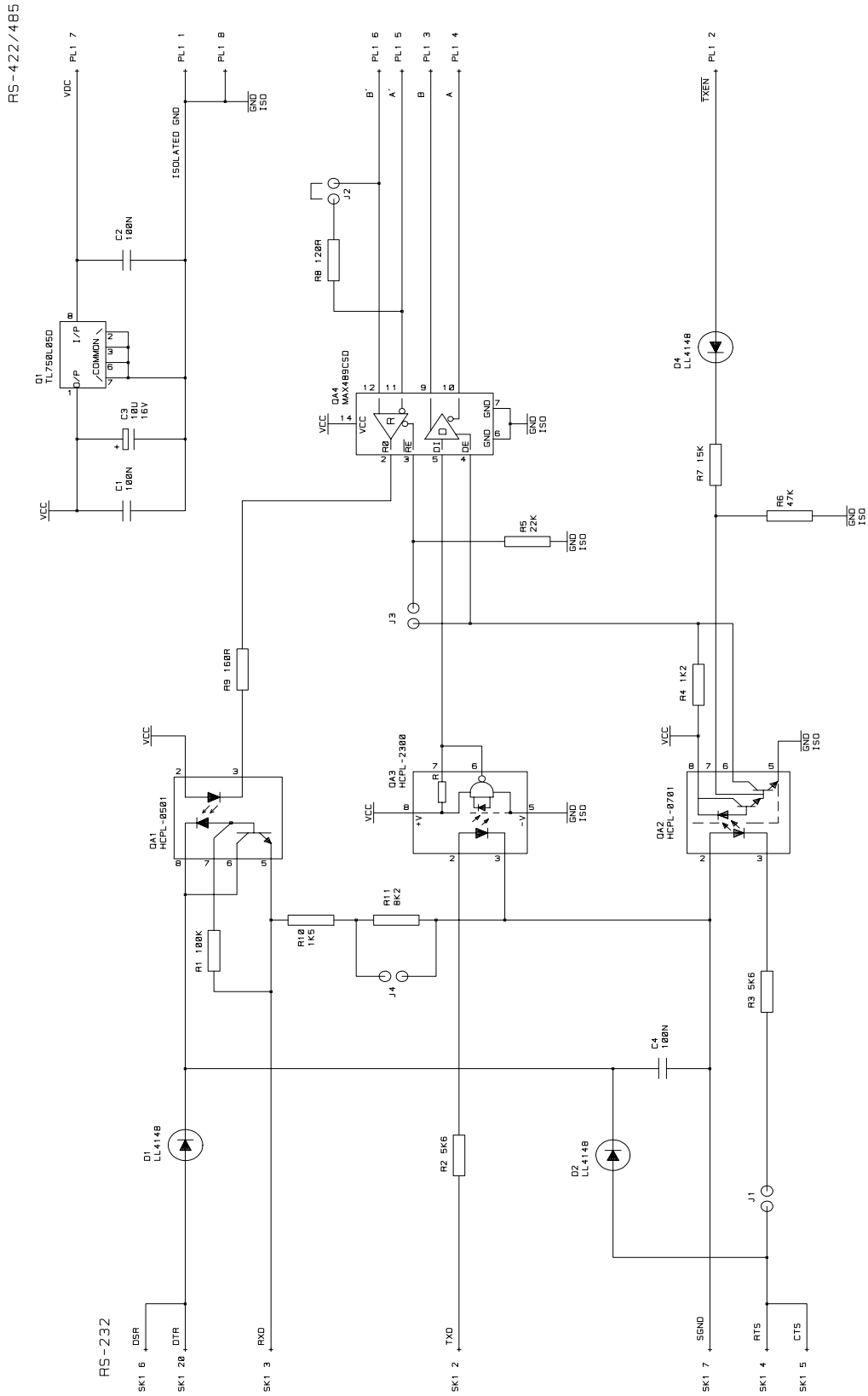

**FIGURE 5.1 MODEL 485Fi CIRCUIT SCHEMATIC**

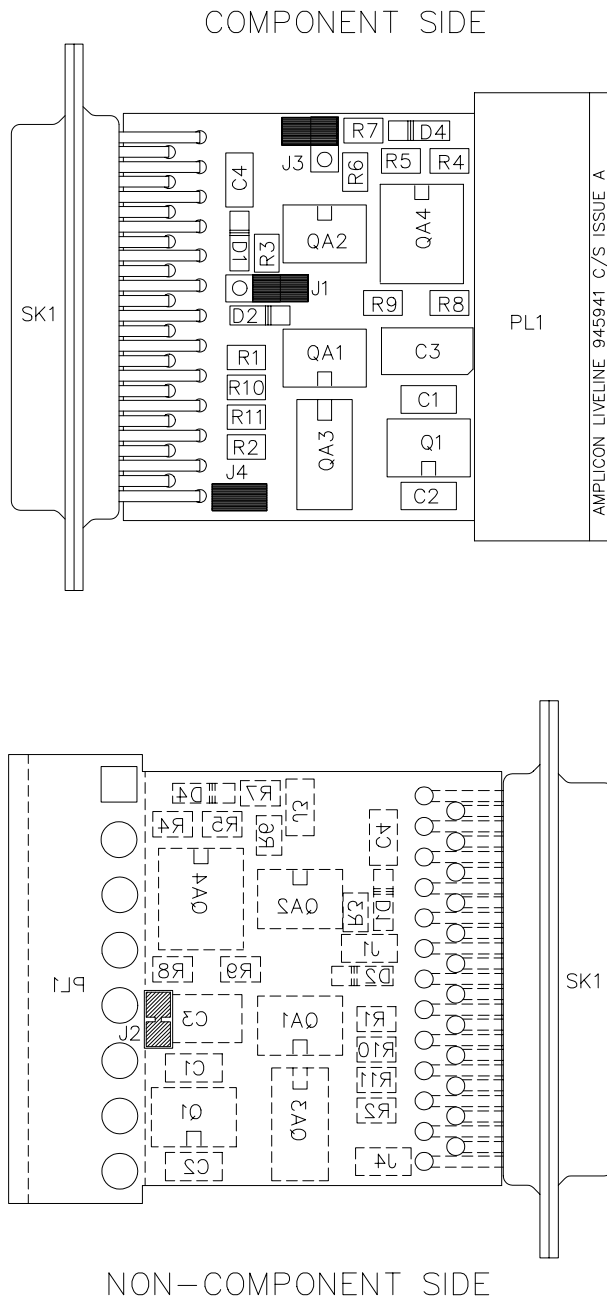

**FIGURE 5.2 MODEL 485Fi PRINTED CIRCUIT BOARD LAYOUT**